

BoscoLighting LED Surface Mounted Light Installation Instruction

Introduction

Thank you for choosing BoscoLighting products.

This document aims to guide a qualified installer or electrician in installing of this product to ensure correct function and safety. Note by Law, certain electrical works must be completed by a licensed electrician. Each State maintains their own licensing system, for more information see www.erac.gov.au/index.php?Itemid=516.

Warranty

Your BoscoLighting light fitting is covered by a 3 year warranty. Please retain proof of purchase or register your purchases by sending an email to warranty@boscolighting.com.au by attaching a copy of your purchase invoice, details of the end user (name, company, phone and address) and electricians company and electrical license number.

Warranty will be void if there is any damage due to improper installation, modification to the fitting except from the standard issued parts and features or used for purposes other than the intended purpose and safety precautions and warnings had been disregarded, site issues like voltage surges, vandalism or rodent damage.

Safety Instructions

- First and foremost, do not install or operate the fitting if it appears to be damaged in any way. Please inform your local supplier or send an email to warranty@boscolighting.com.au as stated on the warranty section of this document.
- Before installation, check the installation location if it has an access to an electrical junction box which is

connected to a wall switch. If it does not, you can hardwire internally according to electrical standards.

- Make sure that you have chosen the suitable light fitting with the correct *Ingress Protection (IP)* rating based on the installation location or environment. For more detailed information regarding IP ratings, please refer to the IP rating section below.
- Turn off the fuse/circuit breaker that controls the power to the area or fixtures that you are working on. Turn off as well the light switches on your wall and do not forget to test the electrical wires for voltage presence before you start working to avoid unexpected electrical shock.
- Use proper electrical protective gears and electrical tools during the installation.
- Please do not put any undue stress on the fitting, it is designed to support its own weight only. Not to be used to support hanging items or people.

Installation Instructions

STEP 1: Remove the base plate or the top lid from the light fitting and use it to mark the position of the screw holes and the hole for the power supply line in the ceiling, which should be 30mm.. Use an electric drill to make the holes and ensure you remove any sharp edges on the power supply hole which may cause rubbing or damage to the power cable.

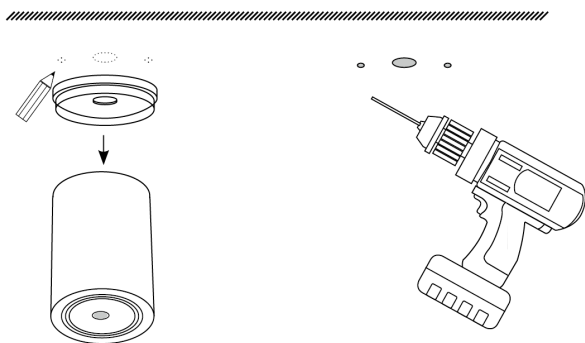

STEP 2: Position and install the set screw to fix the base of the light fitting into the ceiling then connect the power cables.

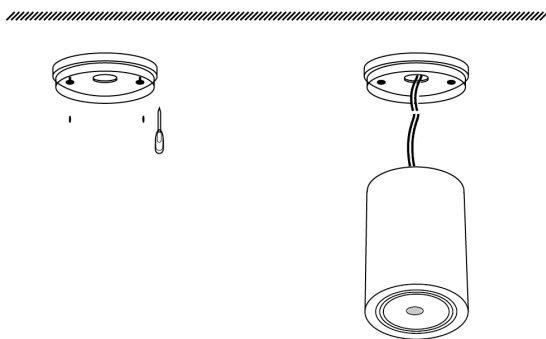

STEP 3: Connect the light fitting to the base by doing twist to lock. Some designs need to be screwed on the sides to interlock both.

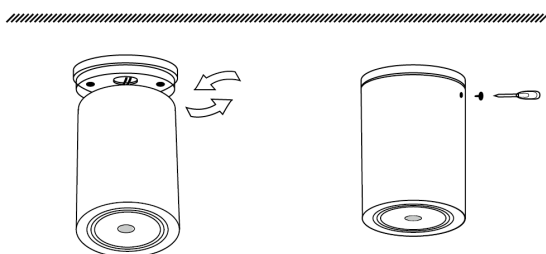

Maintenance

- Make sure that the relevant power circuit has been turned off and light fitting has been given sufficient time to cool down from use before you start of cleaning the lighting fixture. Cleaning must be done periodically to ensure optimal light output and heat dispersal.

- Use damp clean cloth to wipe the dirt that adhered to the light fitting. Never try to immerse the light fitting in water. Regular cleaning should prevent the need to use chemicals when cleaning, if they are required note that the paint or surface may be damaged, so check on an out of the way spot to see first.
- Use static free gloves when cleaning the luminaire to avoid markings.

IP Rating

This table provides a quick reference on general use of IP ratings:

IP	Protection	Details
20	Ordinary	LED lights are suitable for all indoor dry applications, such as offices, retail shops, bedrooms, living rooms.
40	Not waterproof	Insects are not likely getting in the lights, but there is no protection from moisture.
42	Drip Proof	LED lights are protected from tools and small wires greater than 1 millimetre. The lights can resist a few drops of water.
44	Splash Proof	Lights are suitable for bathrooms and other applications where water spray is a risk
54	Dust Proof, Splash Proof	Lights have protection against dust and splash, making it suitable for general outdoor use or damp indoor environments.
64	Dust Tight, Splash Proof	Products are fully protected against dust ingress. Also, these lights are protected against water splashing from any direction.
65	Dust Tight, Jet Proof	Products are completely dust tight, as well as protection against low-pressure water jets from any direction.
66	Dust Tight, Watertight	Products are completely dust tight, as well as protection against higher pressure water jets from any direction.
67	Dust Tight, Watertight	Products are completely protected against solid particles, and can be submerged up to 1m in water for up to 30 mins.
68	Dust Tight, Pressure Watertight	Products are hermetically sealed and suitable for continuous immersion in water.

Disclaimers

- BoscoLighting is not liable where :
 - There is product malfunction and or any damages caused by improper use or installation.
 - Installation has not completed by licensed electricians.
 - Safety instructions have not been properly followed.
 - Paint has been damaged due to cleaning chemicals.

-
- Damage due to site issues such as voltage surges, rodent damage or vandalism.
 - IP rating reference table has been included on this document to provide guidance for applicable IP rated lights to be used based on the installation environment. Kindly be advised that the lights are not specifically designed to be installed on hazardous and or corrosive areas.
 - Lights have been designed to operate at an ambient temperature of -10°C to 45°C. Usage outside of this range may have undesired effects including shortening of product life.
 - Lights are only to be repaired under guidance of BoscoLighting, any damages resulting from unauthorised alterations or repairs is expressly not permitted and will result in BoscoLighting Warranties and Liability being void.
 - BoscoLighting has the right to modify or obsolete the design of its products for quality improvement or due to supplier constraints.
 - Products may appear different to product data sheets or installation instructions.