

WAH2 Flush Mount Kit

LED Downlight Accessories

WAH2 Flush mount kit allows WAH2 slim trim downlight to be installed into plaster ceilings flush with the ceiling and without protrusion.

Order together with **WAH2** downlight to ensure truly trimless elegant finish.

Suitable for ceilings with holes sized 110-150 mm.

Dimension(mm): L180*W135*H17

Contact us for more information!

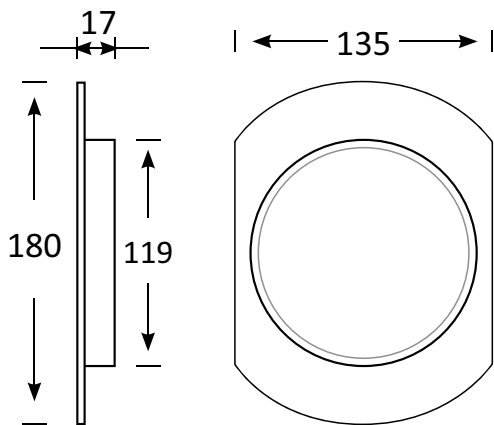

BLTK-WAH2-10



BLDL-WAH2-10

WAH2 Narrow trim downlight

7W, 595lm, D81*H95, cutout:D75

10W, 850 lm, D81*H110, cutout:D75

15W, 1275lm, D81*H135, cutout:D75



Input Voltage (V): AC 200-240

Connect: AU Standard Flex & Plug

CCT: Warm White, Neutral White, Cool White
(2700K-6000K)

CRI:>80 or 92

Viewing Angle: 20/36/60

Dimming: Various dimming options available on request

IP Rating: 44

Installation guide for WAH2 Flush Mount Kit

Follow these instructions for installing kit with WAH2 downlight in order to create a flush mounted effect.



Materials required:

WAH2 downlight; WAH2 Flush Mount Kit; Patching plaster/compound; Knife; Putty knife; Scrapers; Sandpaper; Paint and brush



Step 1. Apply sufficient plaster to the wings to ensure it holds securely in the ceiling, and place the kit to the ceiling cavity and pull down onto the ceiling surface.

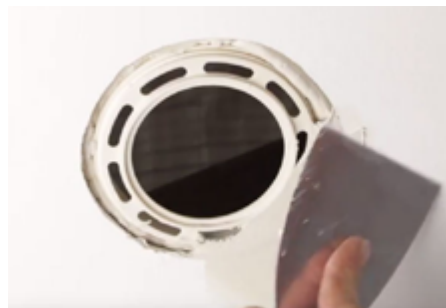

Step 2. Apply the first coat of plaster. Hold the plate ensuring it doesn't move. Remove any excess product from the inner ring and scrape the surface until it's flush with the ceiling.



Step 3. Then apply a slightly wider second coat of plaster and flatten it out to make the repair less visible. Repeat the process with extra layer of finishing compound.



Step 4. Once dried, sand the area smooth with the sandpaper block.



Step 5. Prime and paint. Clean any excess product from the inner ring.



Step 6. Install the WAJ2 narrow trim downlight.